

04
06
08



01

38

43

45

47

50

22

30

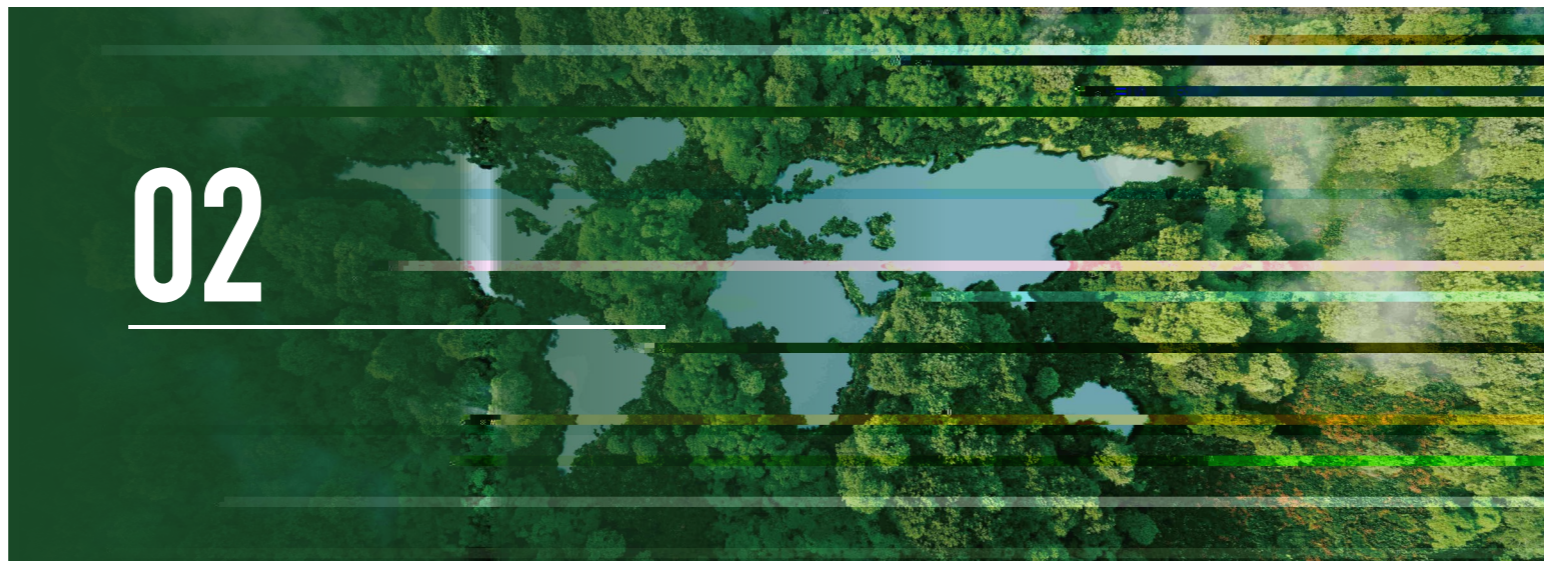

02

54



03



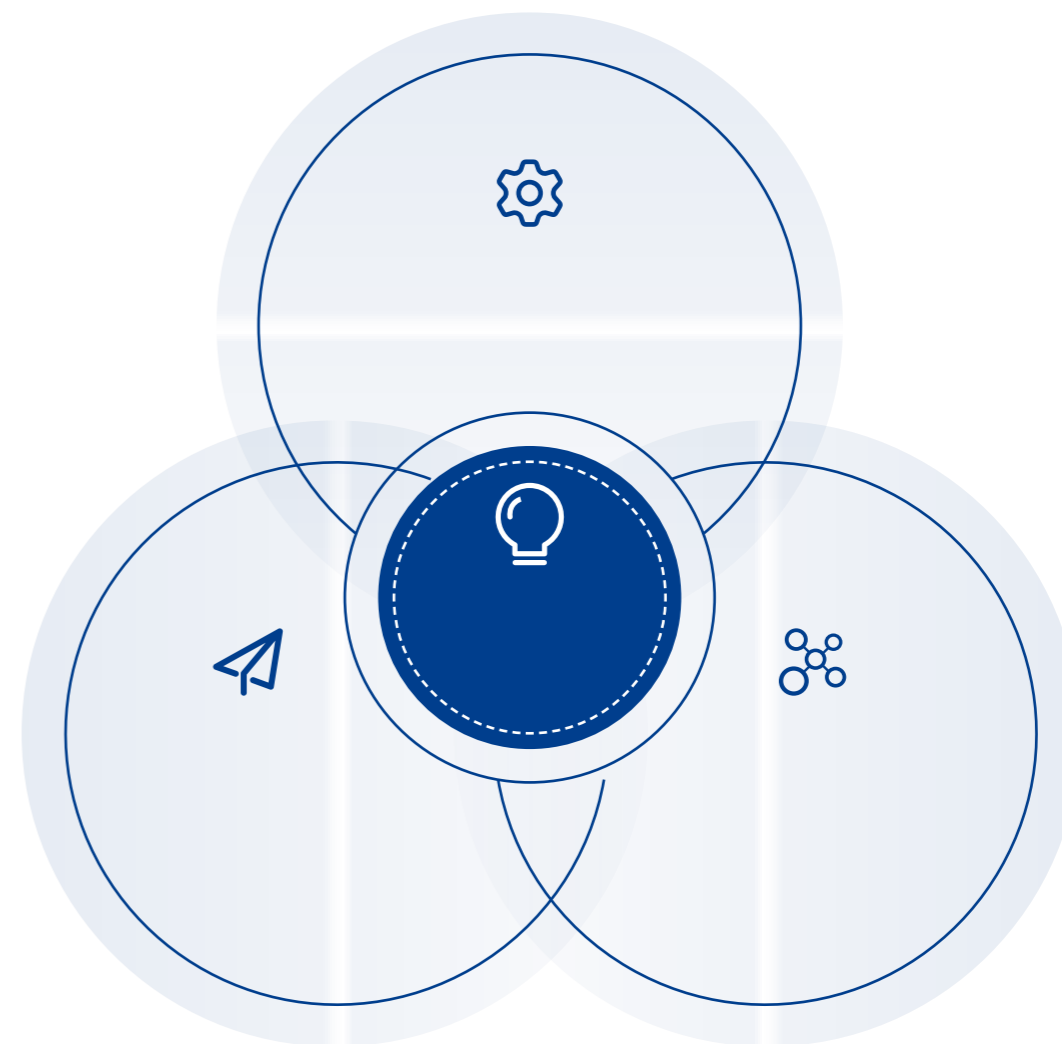



*Memorandum of Cooperation on the
Cooperative Development of Intelligent
Low-carbon Urban Energy
Infrastructure in the China-Singapore
Guangzhou Knowledge City.*



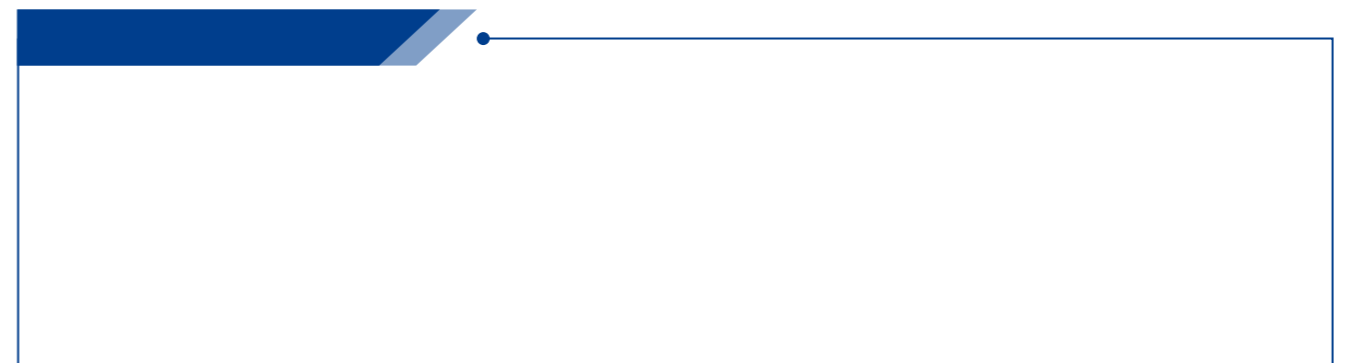



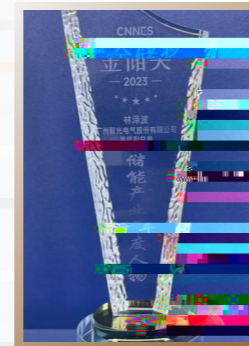
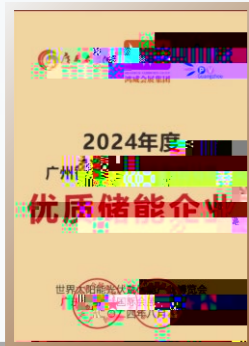
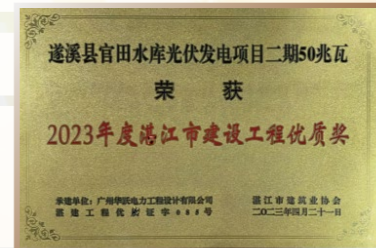
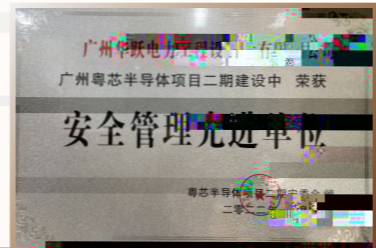
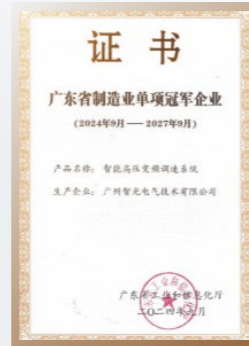

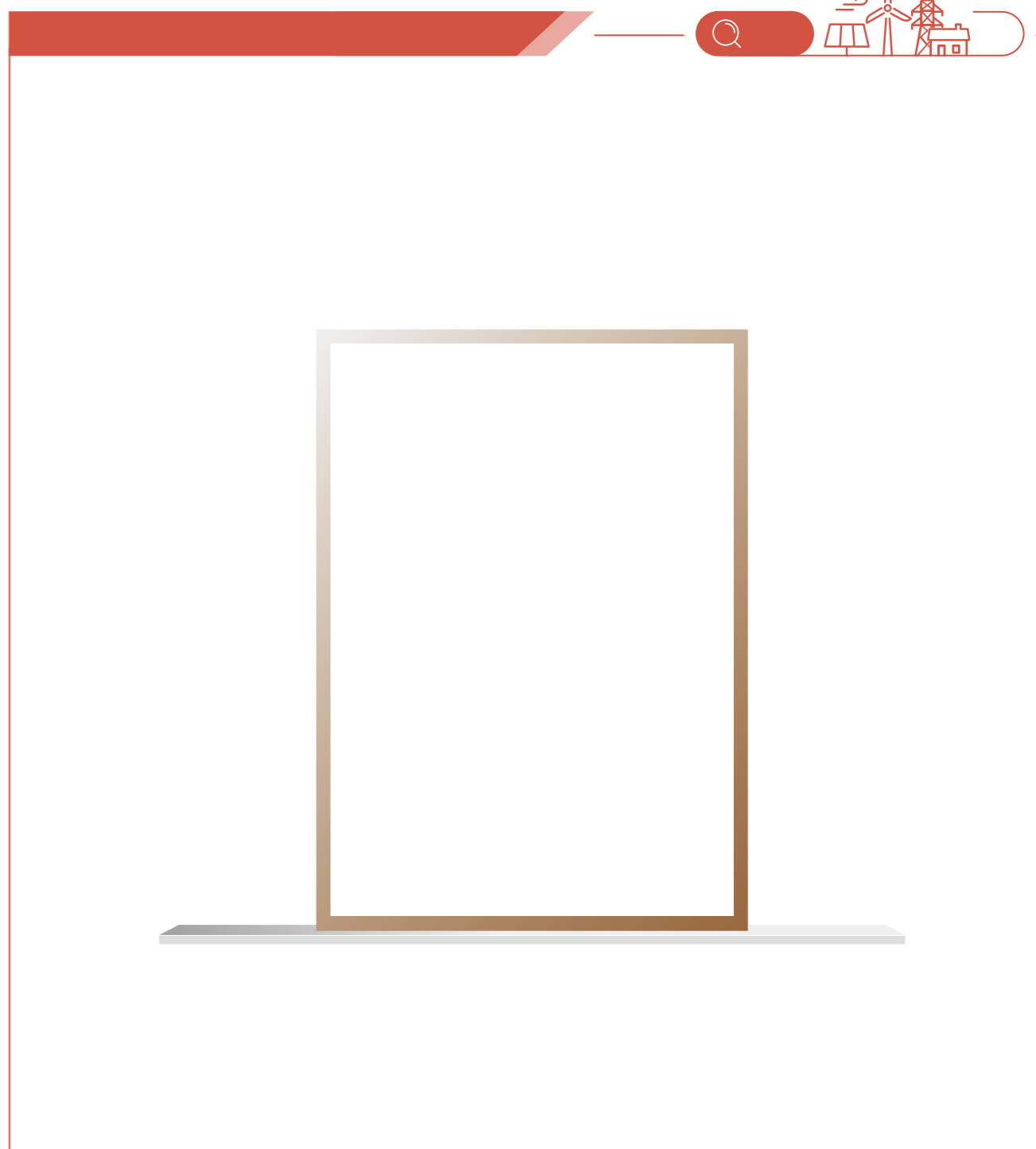
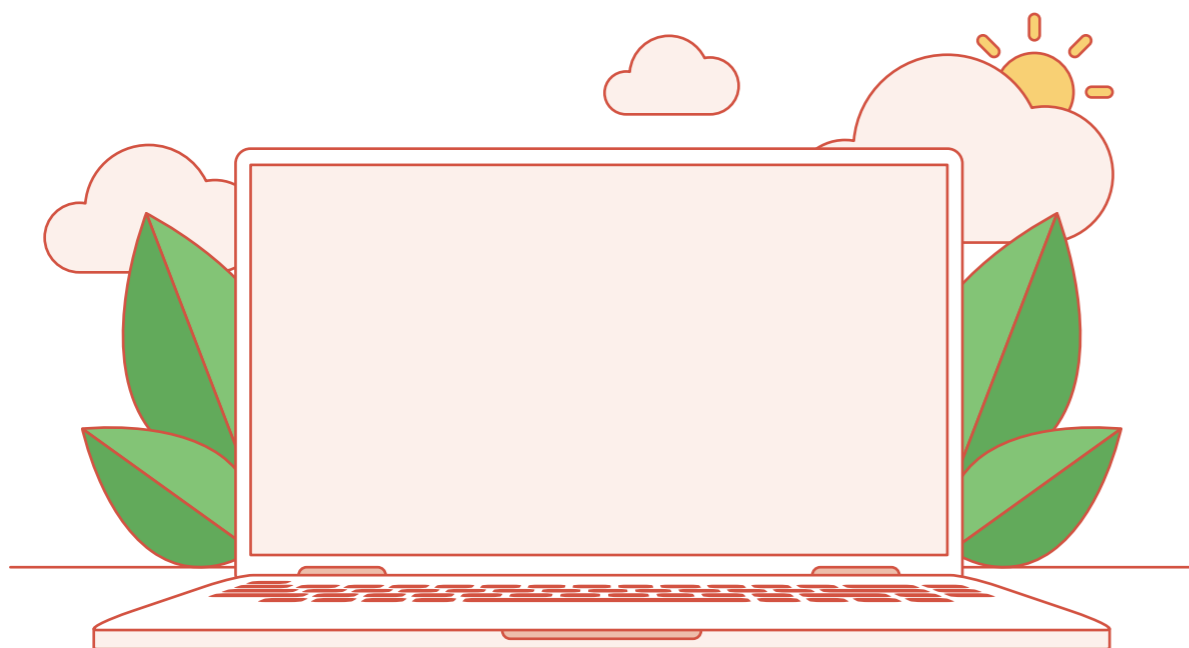







People's Republic of China
High-Quality Development of the New Energy Storage Manufacturing Industr

The Energy Law of the
Action Plan for the





Memorandum of Cooperation on the Cooperative Development of Intelligent Low-carbon Urban Energy Infrastructure in the China-Singapore Guangzhou Knowledge City

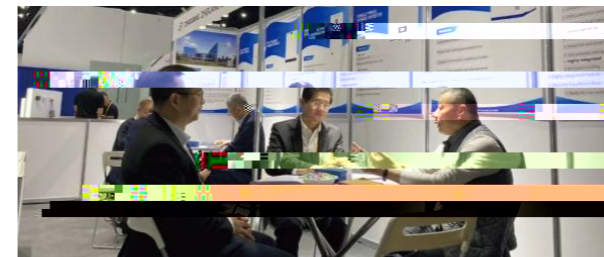

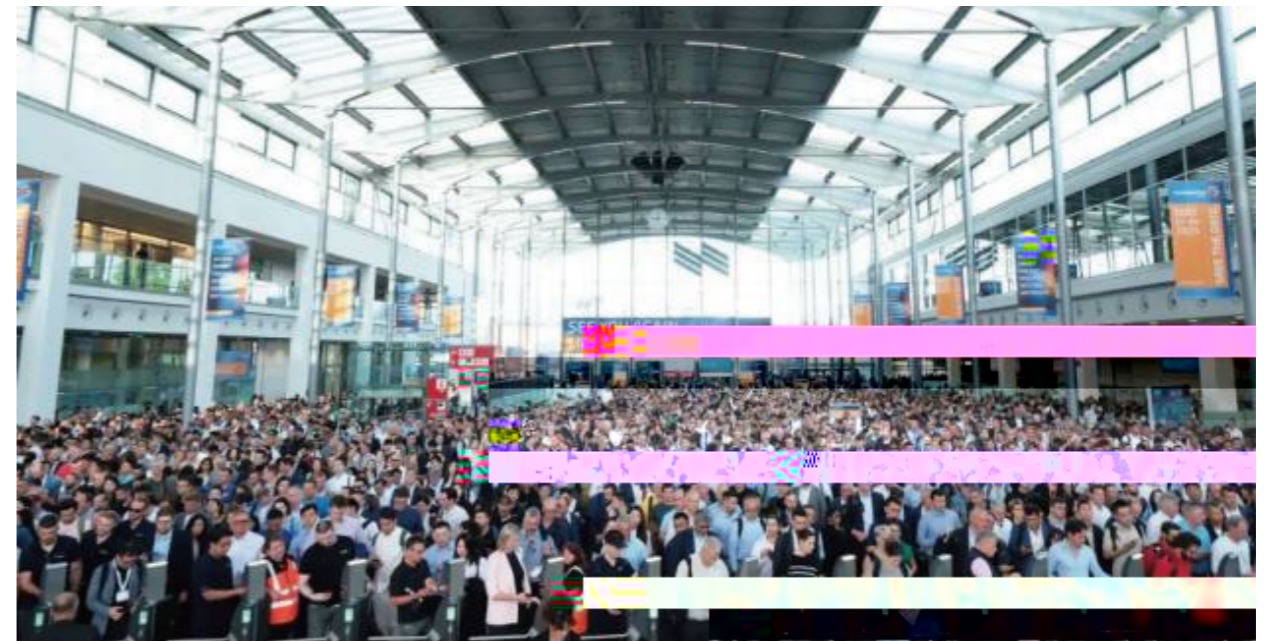
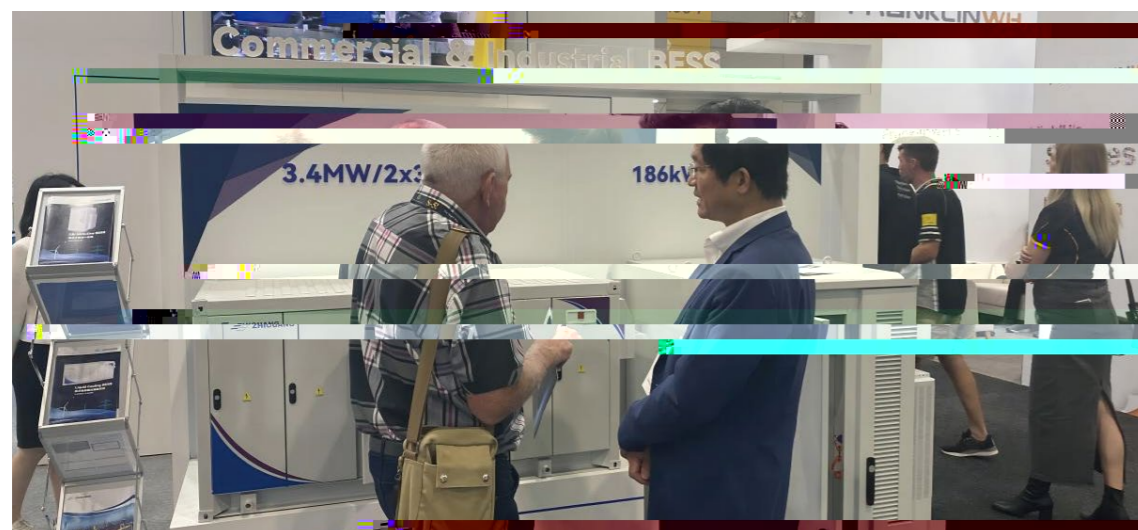

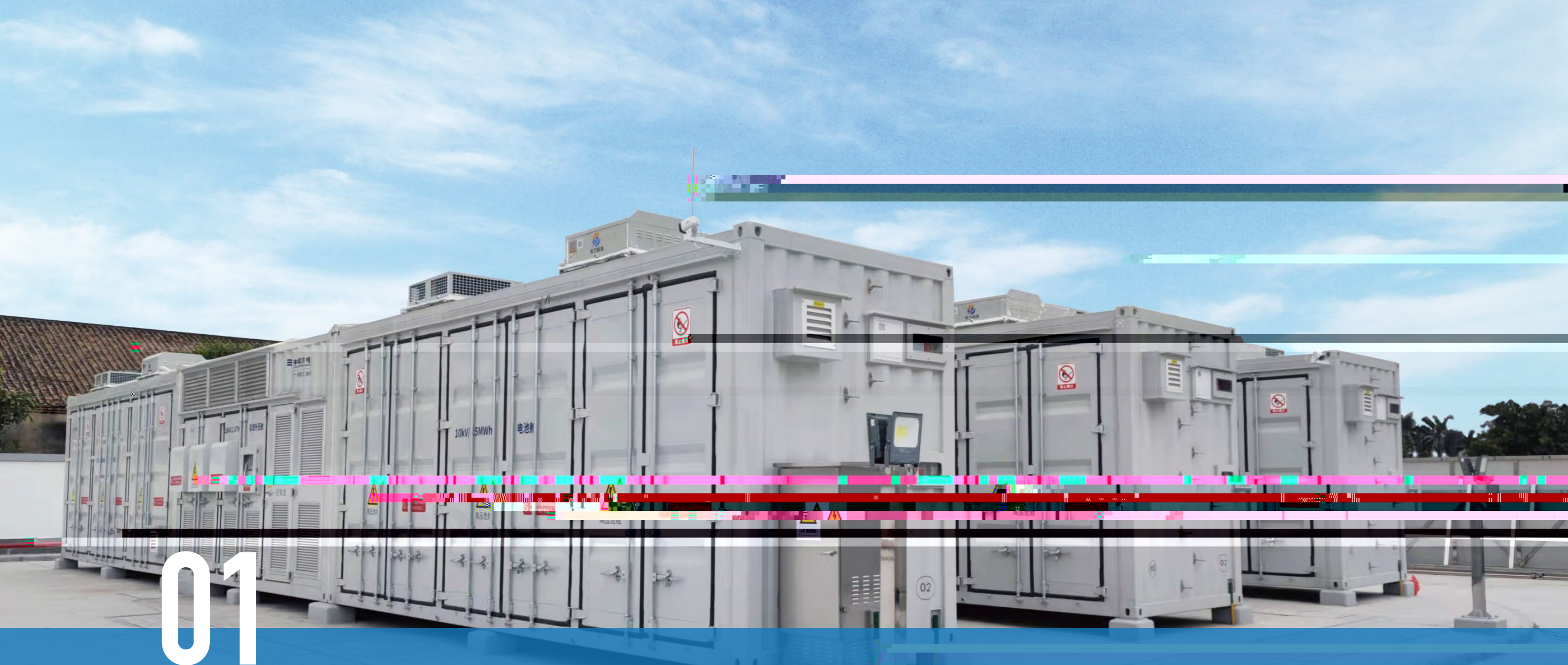

01

Chapter 1 Corporate Governance -





Detailed Rules for the Work of the Strategy and ESG Committee

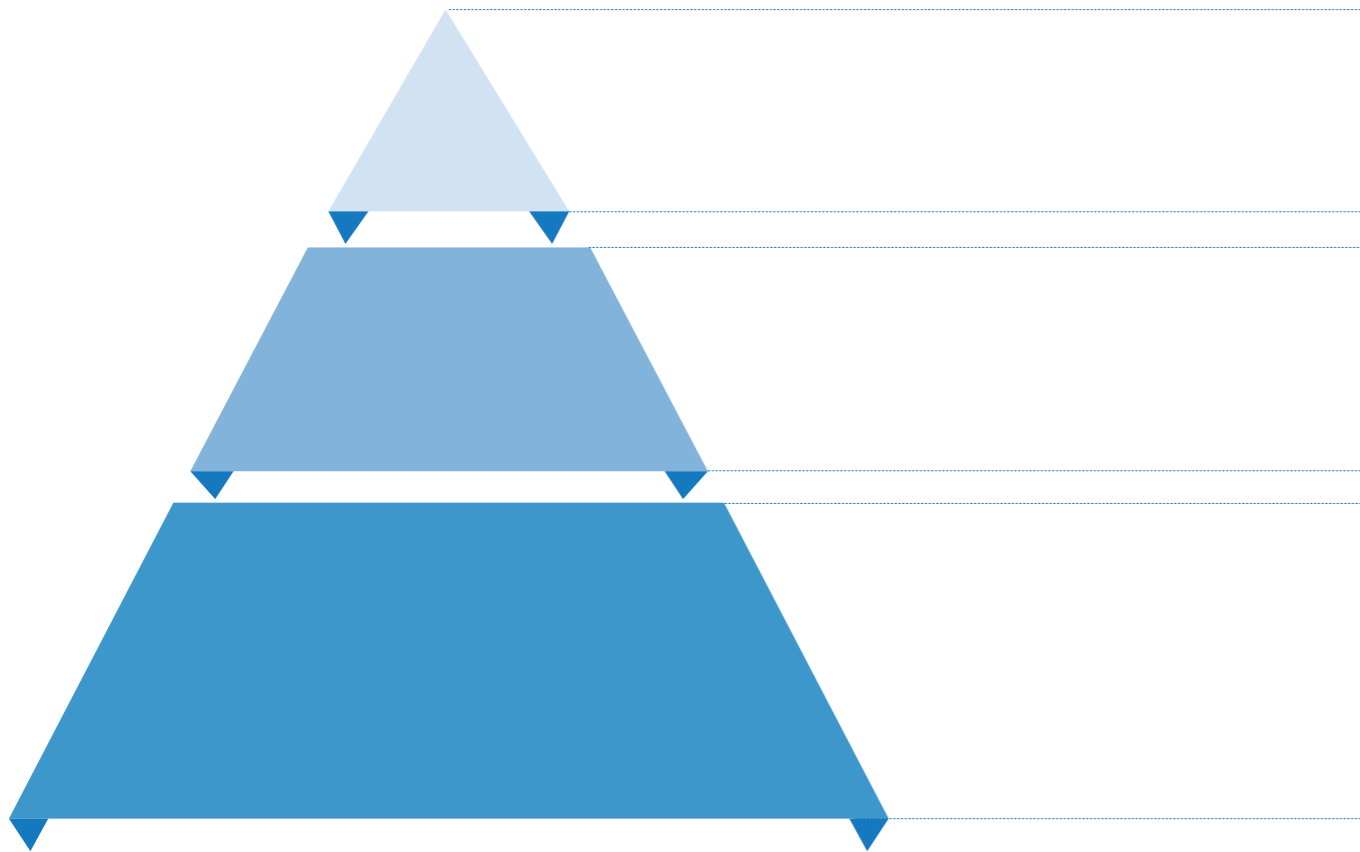



Shenzhen Stock

Exchange Self-Regulator Guidelines for Listed Companies No. 17 - Sustainability Repor (for Trial Implementation) GRI3: Material Topics,

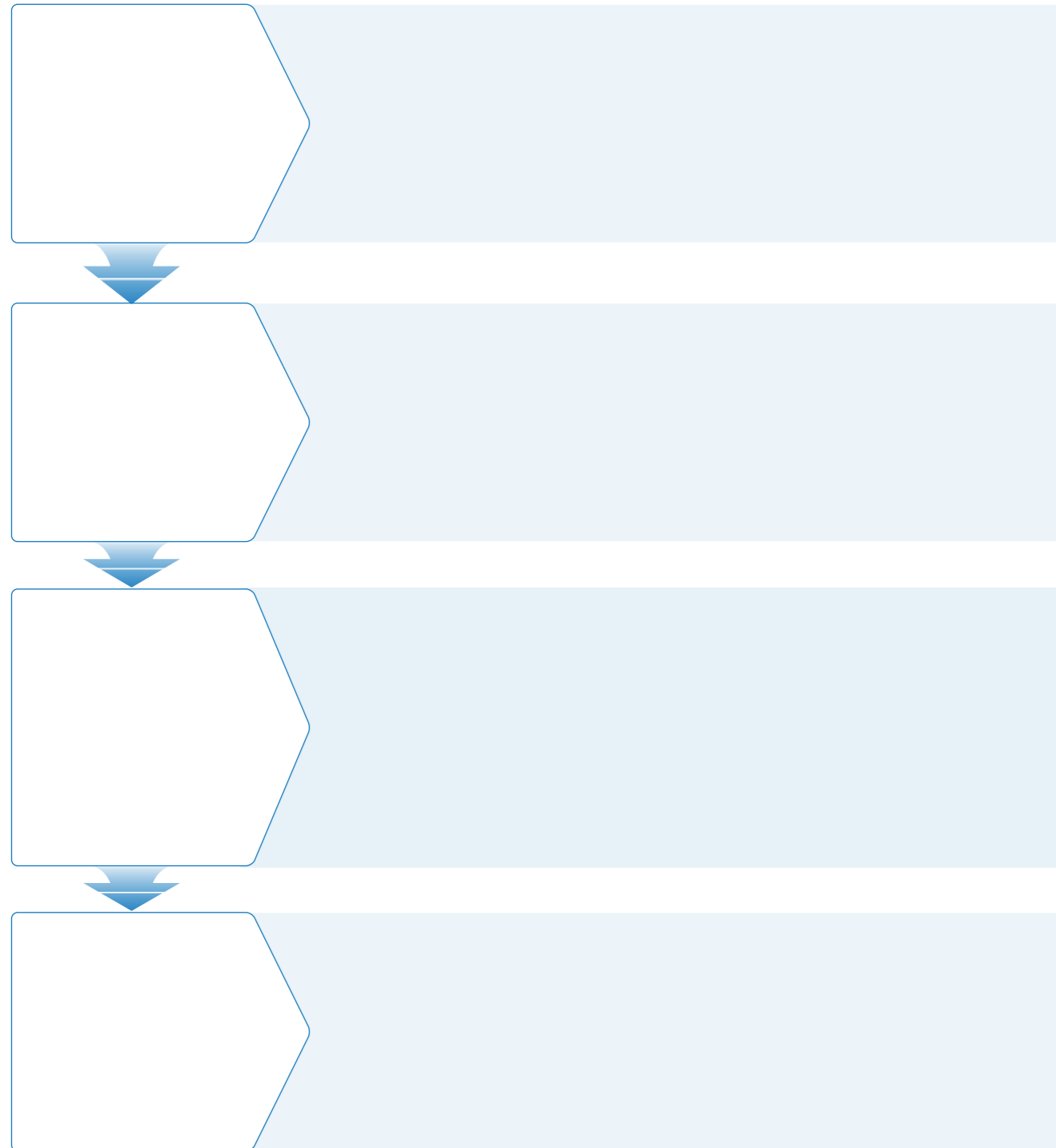

<ul style="list-style-type: none"> ⊙ ⊙ ⊙ ⊙ ⊙ ⊙ ⊙ 	<ul style="list-style-type: none"> ⊙ ⊙ ⊙ ⊙ ⊙ ⊙ ⊙
	<ul style="list-style-type: none"> ⊙ ⊙ ⊙ ⊙ ⊙ ⊙ ⊙



Company Law of the People's Republic of China

Securities Law of the People's Republic of China,

Articles of Association, Rules of Procedure for General Meetings of Shareholders, Rules of Procedure for the Board of Directors, and the Rules of Procedure for the Board of Supervisors.

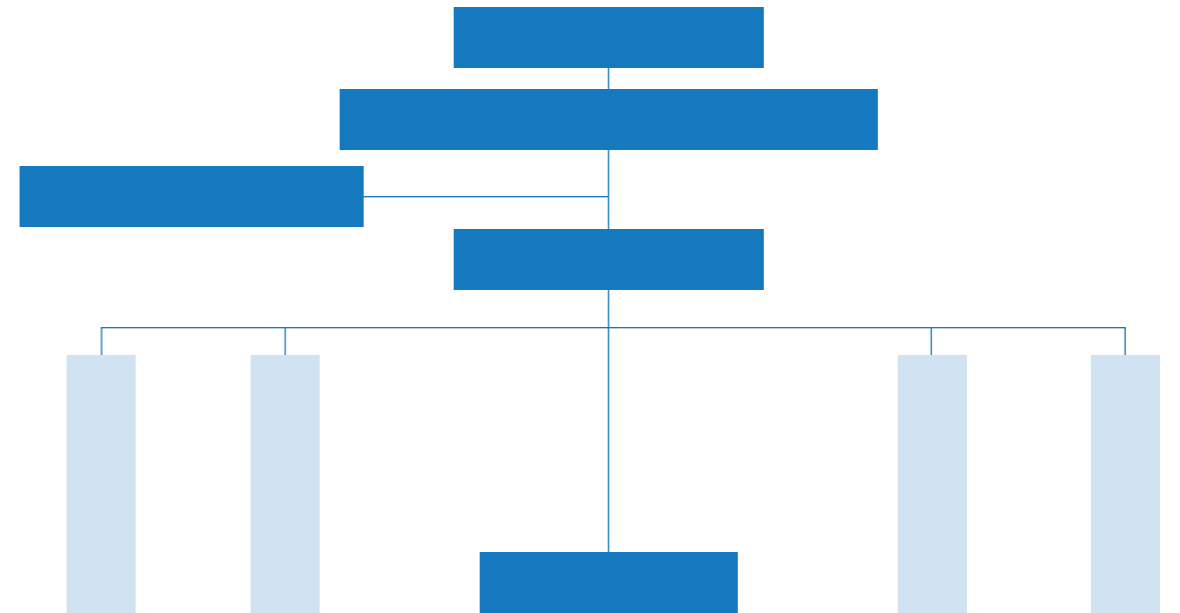

Articles of Association

Rules of Procedure for General Meetings of Shareholders.

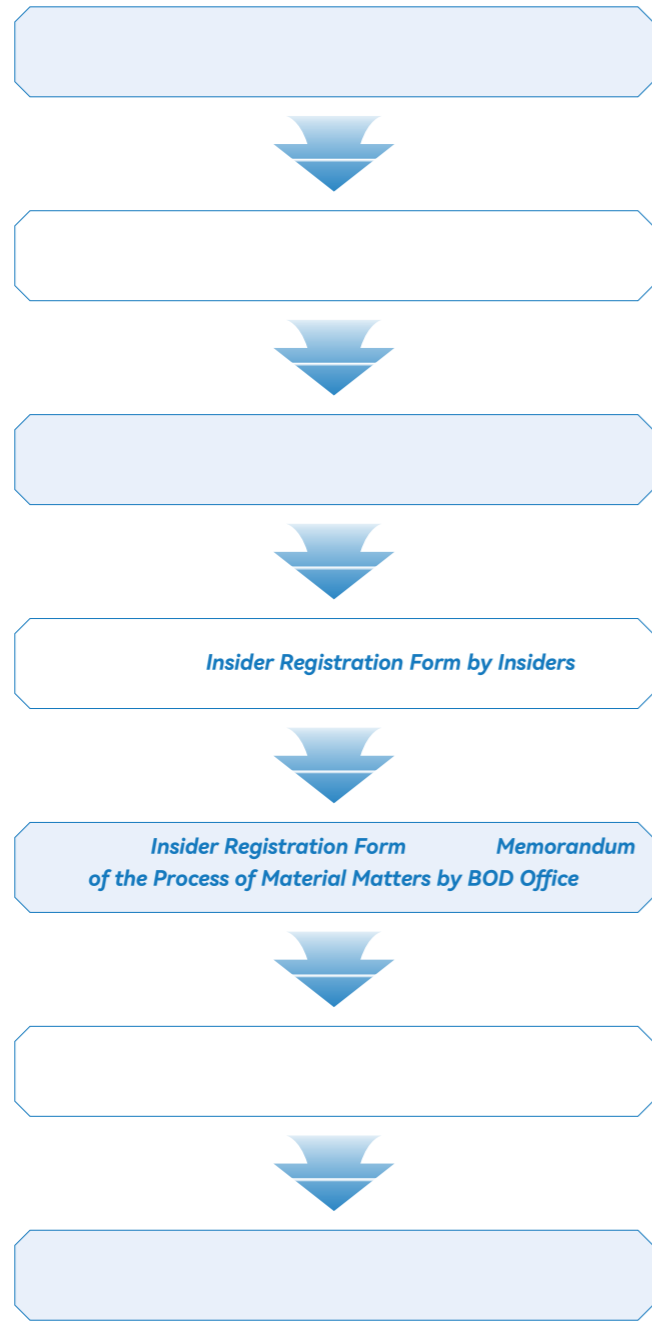

		4
		131



Investor Relations Management System
Guidelines on Investor Relations Management of Listed Companies

Regulations on Handling of Investor Complaints

		2
		7
		300
		6
		138
		138
		94.52



		1	1	0.8
		7,877.92	7,827.04	6,261.63



		1
		6
		155

02

Chapter 2 Environment - Beautiful Homeland:





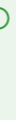

124,119.58

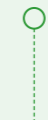

116,047.76



3,071.81

•

•

•
•



-
-





		189.8
		4.48
		0
		0
		100
		100
		100
		72
		376
		250



Q

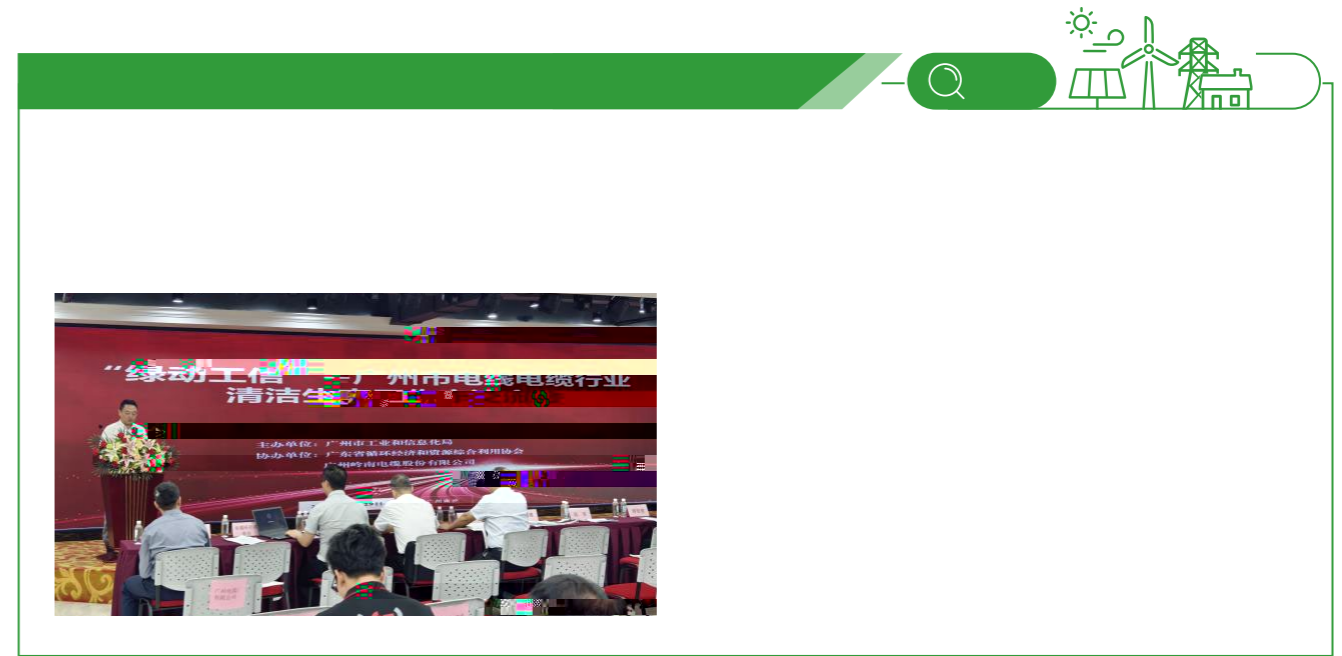

Measures

Administrative Measures for Non-conformity, Corrective and Preventive



01 Job Operation Procedures

02

03

04

05

06

		108,873
		52



Law of the People's Republic of China on Prevention and Control of Environmental Pollution by Solid Wastes
Measures on the Management of Hazardous Waste Transfer Manifests.

- ▶
- ▶
- ▶



<p>危险废物</p> <p>主要成分:油漆、酒精 类别: HW49</p> <p>化学名称: 油漆桶、酒精罐</p> <p>危险情况: 毒性</p> <p>安全措施: 定点存放, 防止泄漏</p> <p>废物产生单位: 广州岭南电缆股份有限公司</p> <p>地址: 广州市南沙区榄核镇人绿路163号</p> <p>电话: 18819325566 联系人: 李勤</p> <p>批次: 数量: 产生日期:</p>	<p>危险废物</p> <p>主要成分: 苯、二甲苯、甲苯、甲醛</p> <p>危险类别</p> <p></p>	<p>危险废物</p> <p>主要成分: 油、烃、水混合物或乳化液 类别: HW09</p> <p>化学名称: 废乳化液</p> <p>危险情况: 毒性</p> <p>安全措施: 定点存放, 防止泄漏</p> <p>废物产生单位: 广州岭南电缆股份有限公司</p> <p>地址: 广州市南沙区榄核镇人绿路163号</p> <p>电话: 18819325566 联系人: 李勤</p> <p>批次: 数量: 产生日期:</p>
--	---	---

		44,351.2
		44,084.4
		185.3
		99.40
		24.86
		24.86
		100

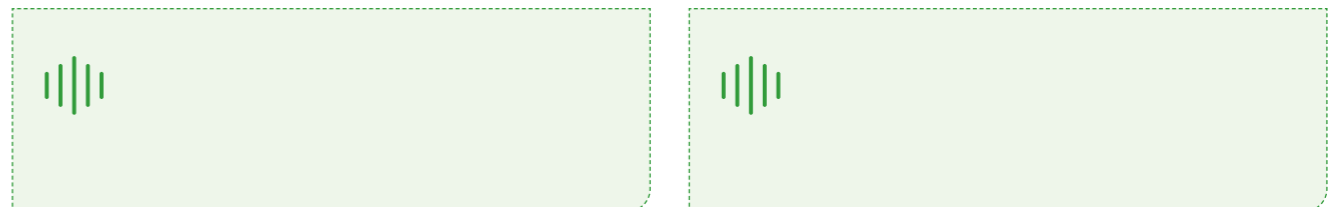

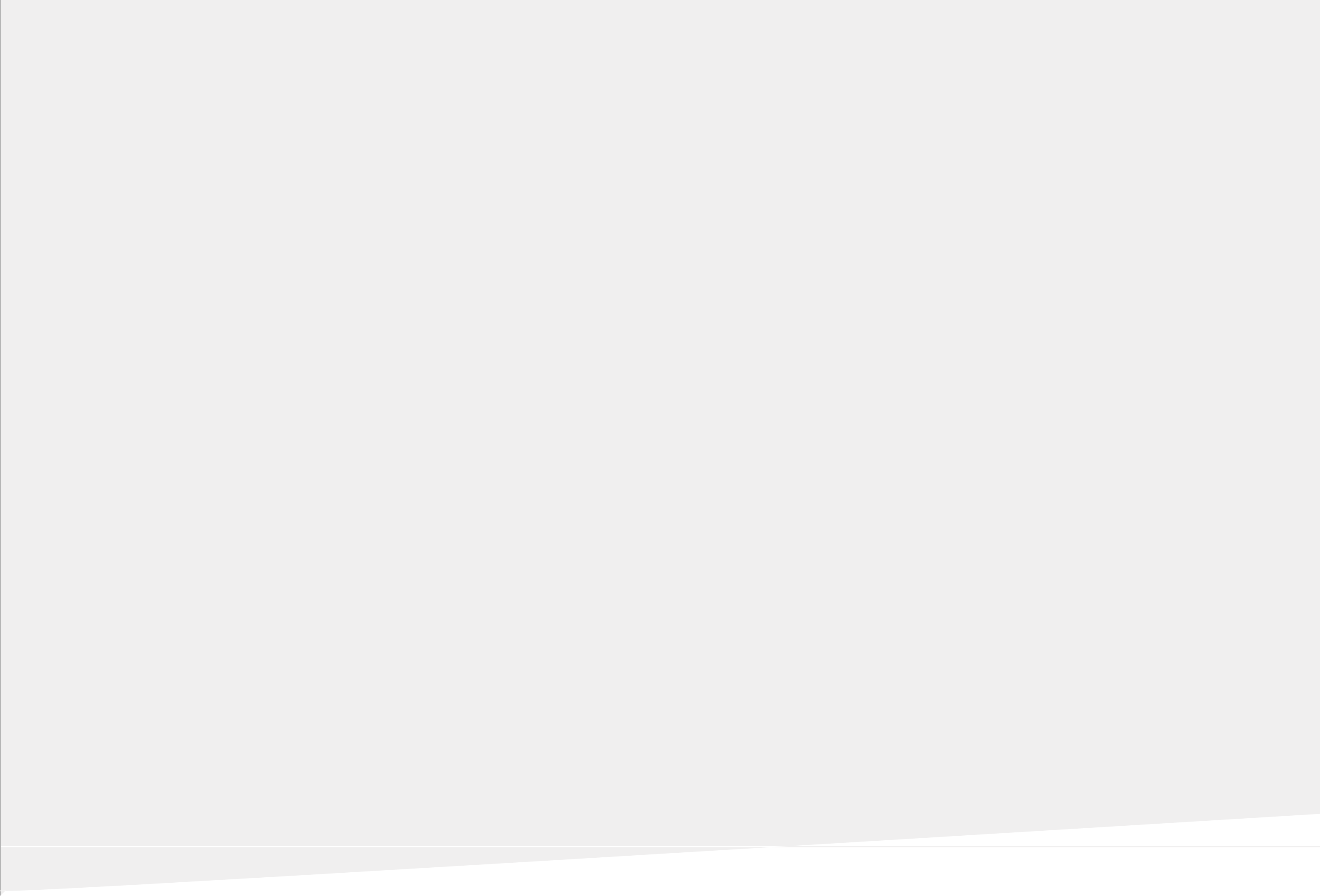

*Management Process for the Consumption of Dead Stock, Operation Instruction Process for Wooden
Packaging, Packaging Specifications of EPE Foam for the Shipping Team, Measures for Handling Management, Warehouse
Management System*

Chapter 3 Society - Collaborative Development:



Regulation on Management of Technical Improvement and Technological Innovation, Administrative Measures for the Initiation of R&D Projects, Regulation on Management of Design and Development, Administrative Measures for Scientific Research Projects, Special Incentive Management Measures, Administrative Measures for the Evaluation and Reward of R&D Projects, Administrative Measures for the Management and Reward of Government Projects Industr -University- Research Institute Management Regulation

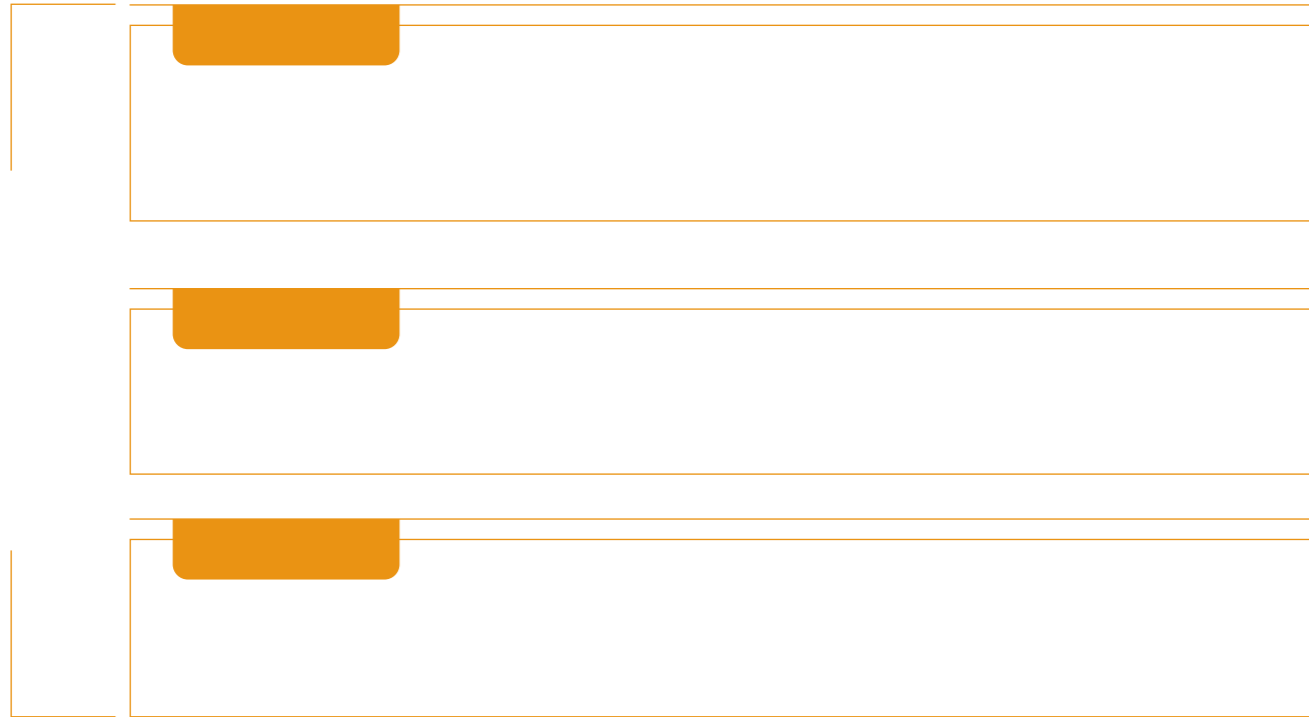

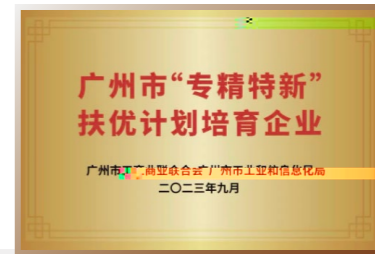
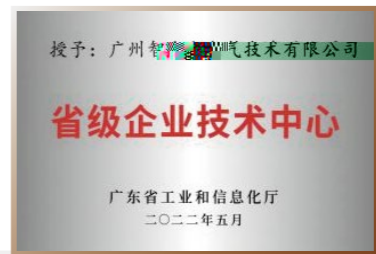
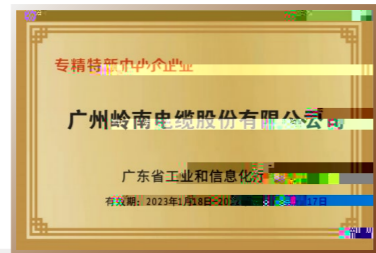
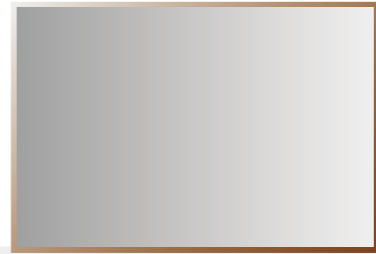
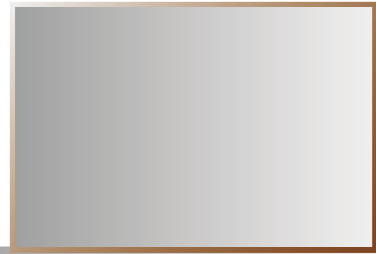

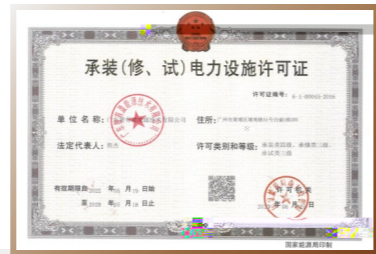
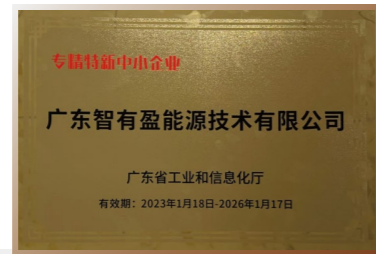

A writing area consisting of a solid orange vertical bar on the left side and ten horizontal orange lines extending to the right.A writing area consisting of a solid orange vertical bar on the left side and ten horizontal orange lines extending to the right.A writing area consisting of a solid orange vertical bar on the left side and ten horizontal orange lines extending to the right.A writing area consisting of a solid orange vertical bar on the left side and ten horizontal orange lines extending to the right.



Orange vertical bar on the left side of a white rectangular area with horizontal lines.



White rectangular area with horizontal lines and a vertical line with brackets on the left side.

-
-
-
-
-

White rectangular area with horizontal lines.

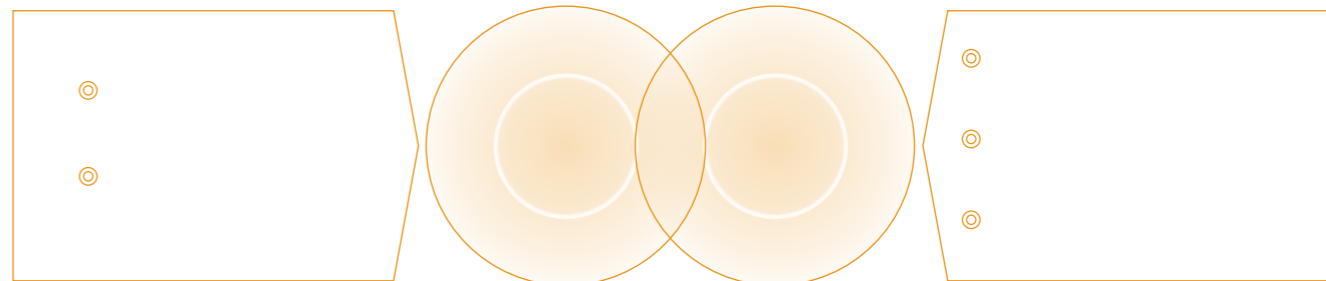
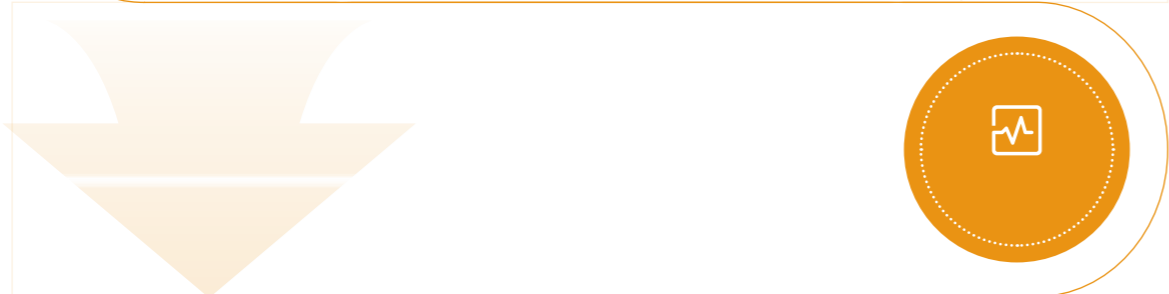
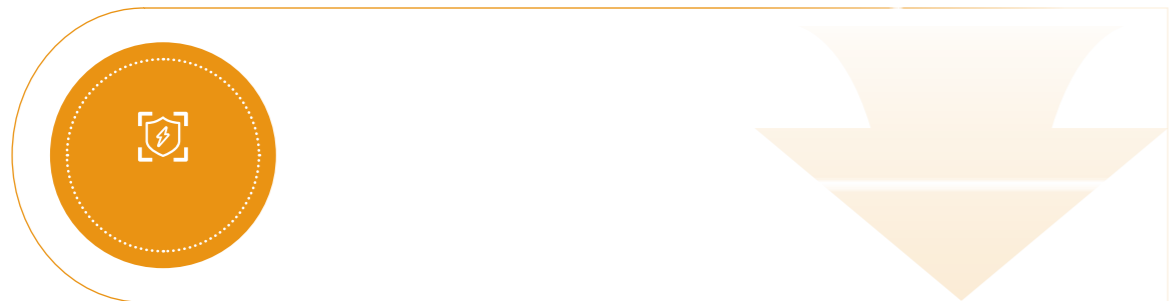



		16,016.52
	%	

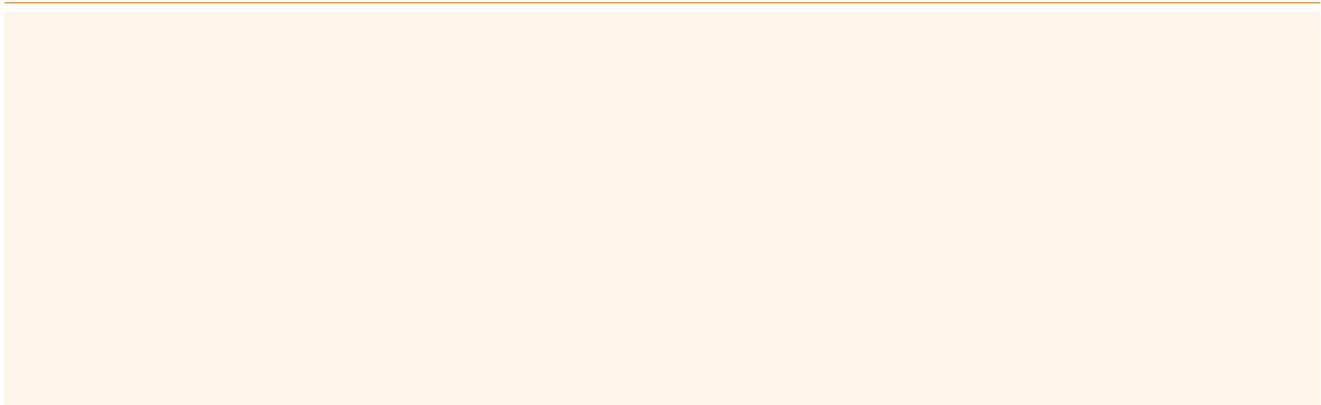
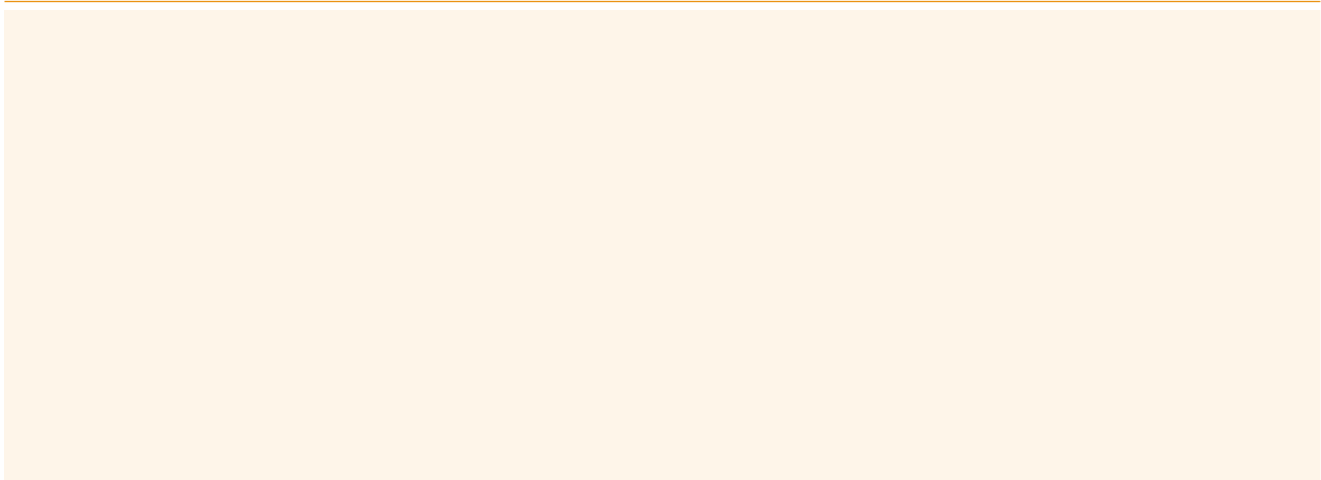
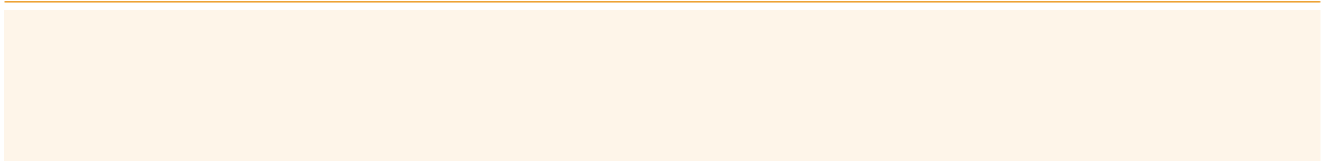



Intellectual Property Management System, Administrative Procedure for the Management of Intellectual Property Documents, Procedure for Management of Intellectual Property Risks, Administrative Procedure for the Handling of Intellectual Property Disputes, Measures for Management of Scientific and Technological Archives, Procedure for Management of Intellectual Property in the Sales and After-sales Process

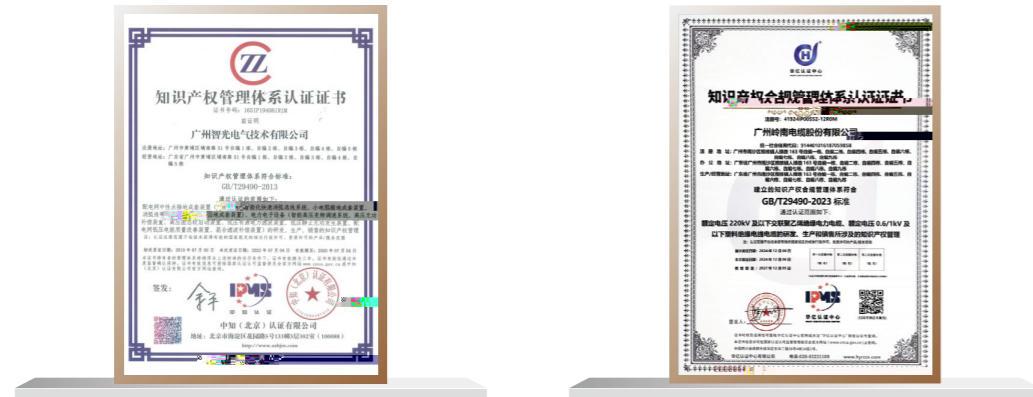

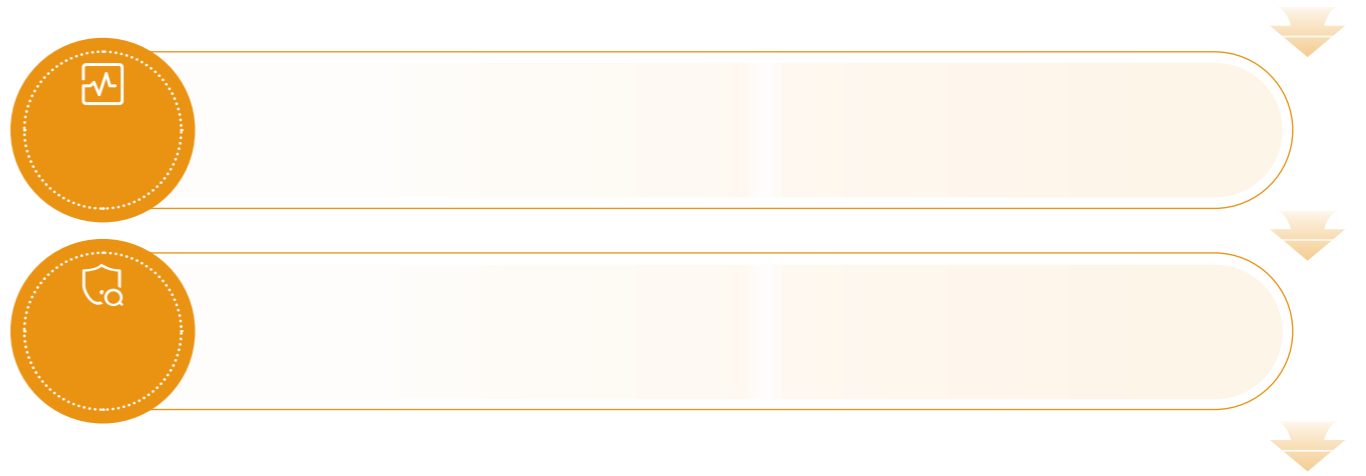





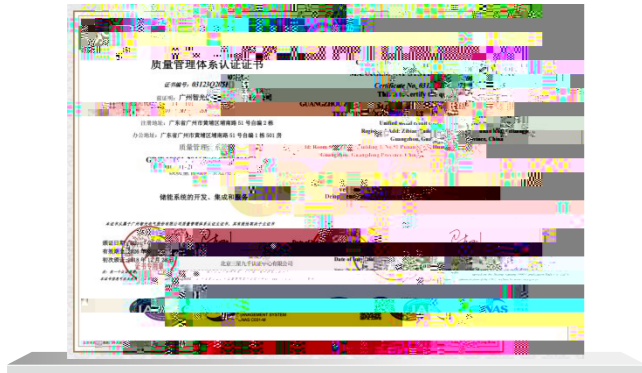
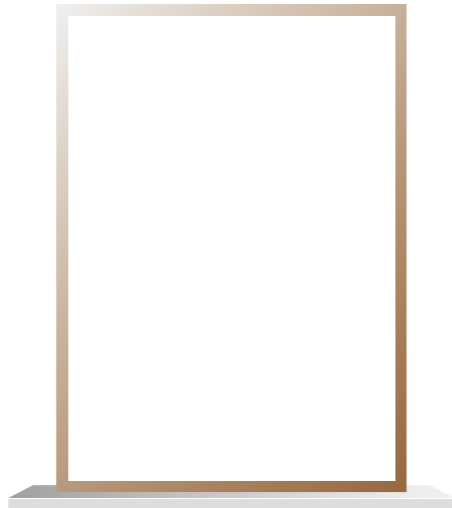



Orange vertical bar on the left side of a lined writing area. Three black dots are positioned on the left margin of the writing area.

Orange vertical bar on the left side of a lined writing area. Three black dots are positioned on the left margin of the writing area.

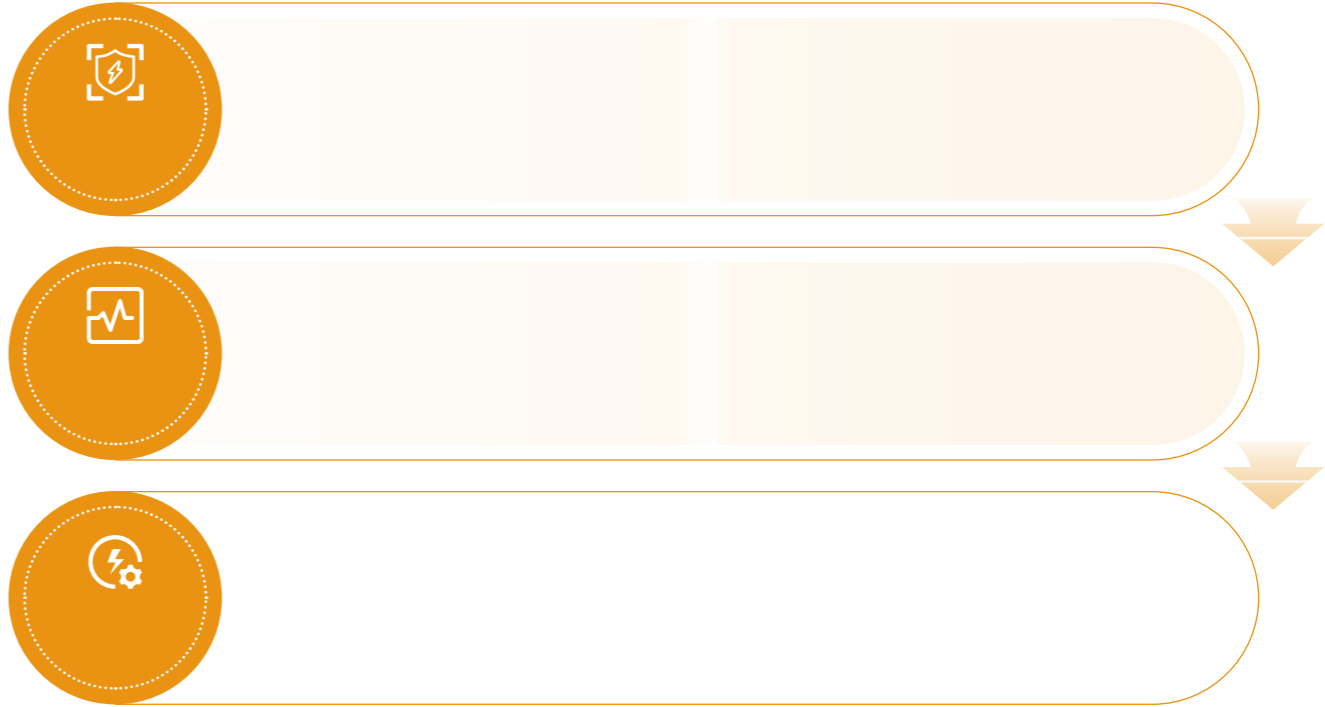

Orange header bar				
		23	20	24
		3	3	4
		22	16	

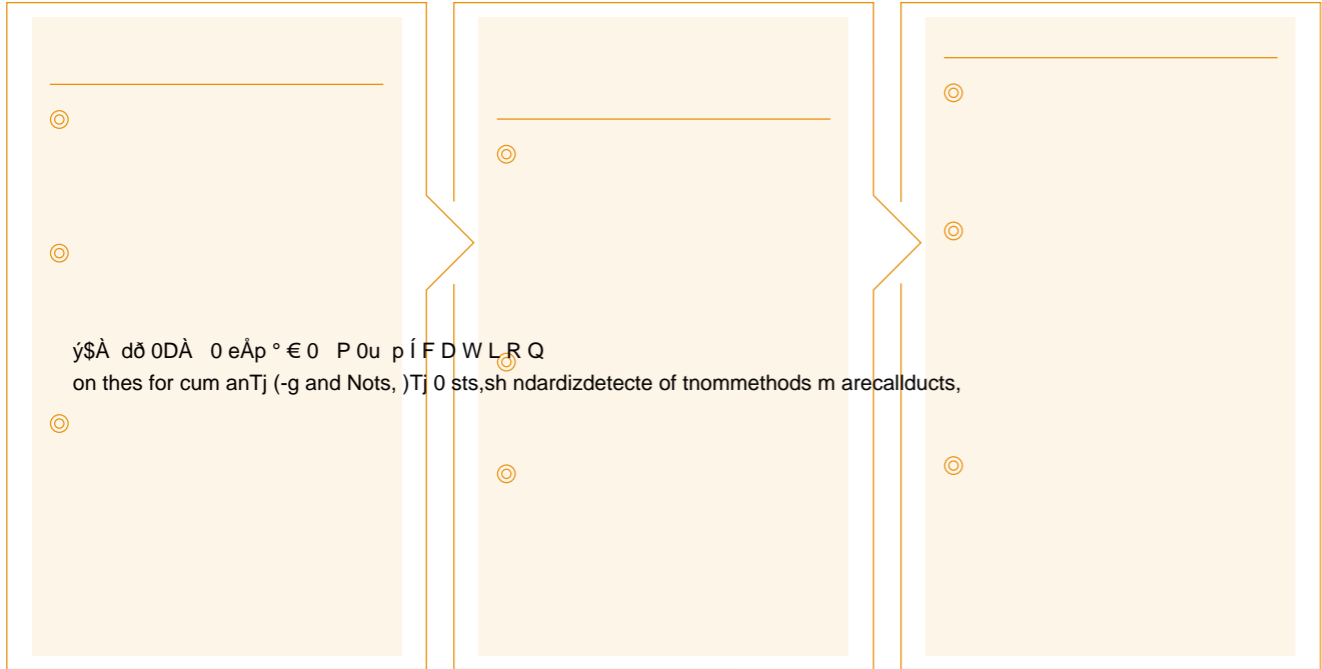

ý\$À dð 0DÀ 0 eÅp °€0 P 0u p ÍFDWLRQ
on thes for cum anTj (-g and Nots,)Tj 0 sts,sh ndardizdetecte of tnommethods m arecallducts,





Quality Commitment Letter



Catalog for Recommended Products with Advanced Technology in Shipbuilding Industry in Guangzhou



Catalog for Recommended Products with Advanced Technology in Shipbuilding Industry in Guangzhou

广东省船舶工业协会

广州市船舶行业先进技术产品推荐目录（2024年）
评审结果公示

附件：
广州市船舶行业先进技术产品推荐目录（2024年）

序号	单位名称	产品名称
三、船舶配套产品		
序号	单位名称	产品名称
126	广州智光电气技术有限公司	高压岸电源系统

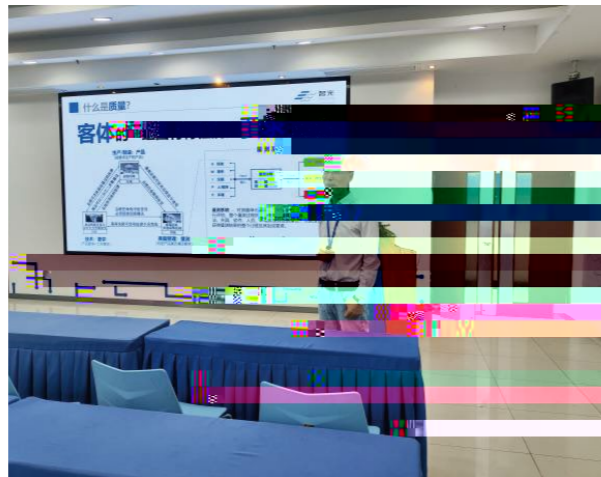



Public Announcement of the Preliminary List of the Famous and High-Quality High-Tech Products in Guangdong Province in 2024.

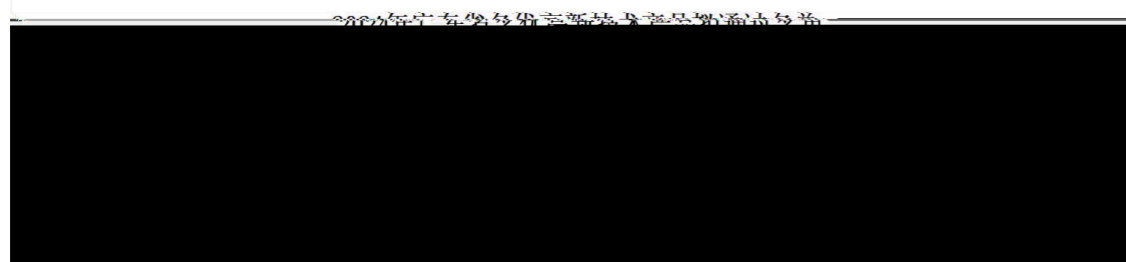

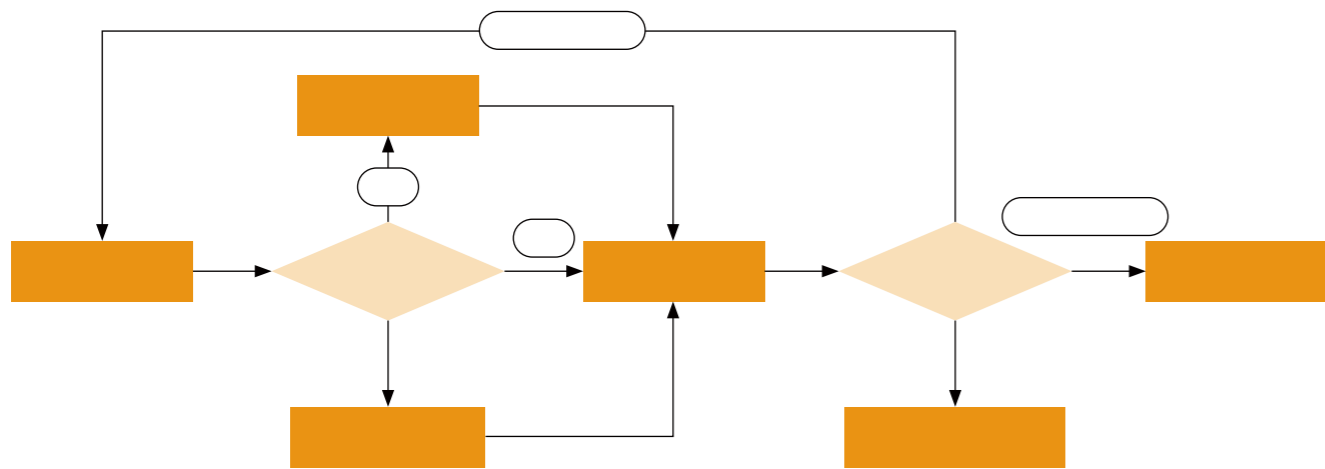

On-site After-sales Service/Safety Operation Instruction Manual, *Regulation on After-sales Business and Service Management*





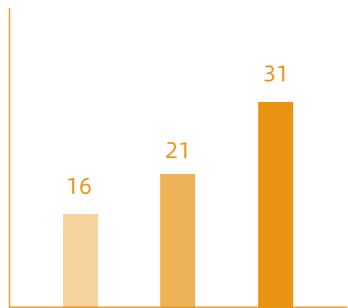

S.A. 

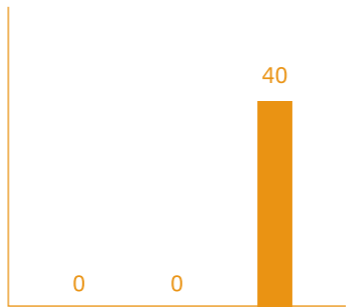
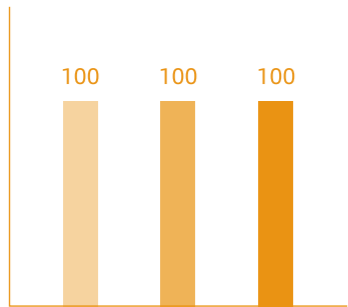
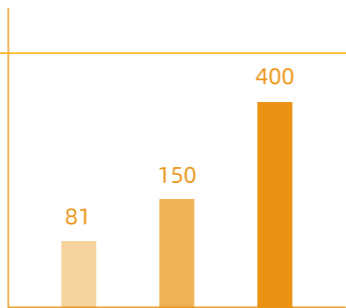

2022





按性别划分			
类别	男	女	合计
无障碍设施	100	100	200
无障碍通道	0	0	0
无障碍卫生间	0	0	0
无障碍停车位	0	0	0
无障碍电梯	110	96	206
无障碍客房	2,142	2,073	4,215
无障碍餐厅	13	17	30
无障碍会议室	90	80	170
无障碍健身房	2	2	4
无障碍图书馆	626	551	1,177

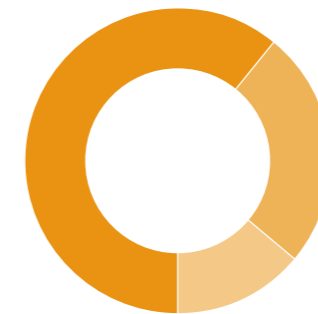
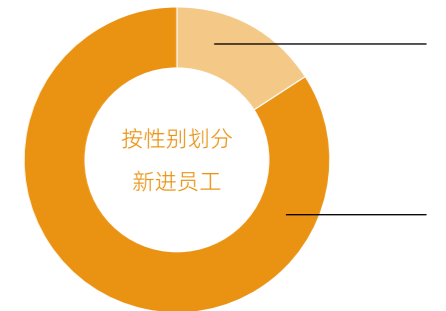
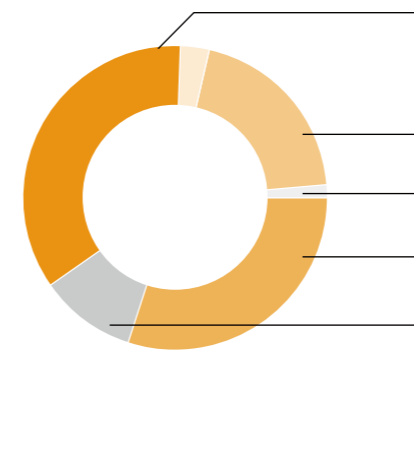
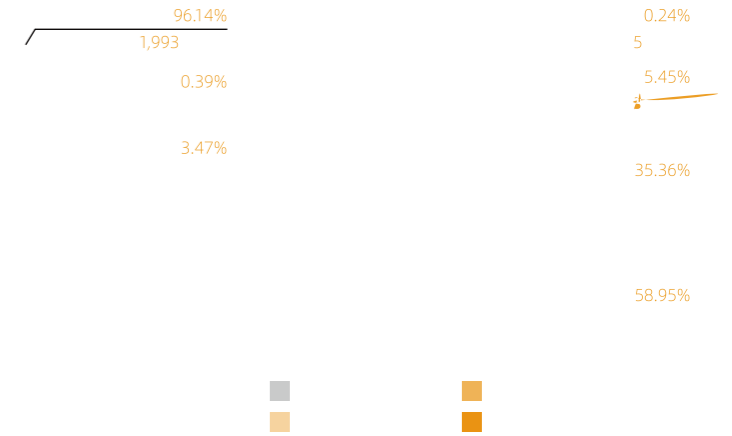
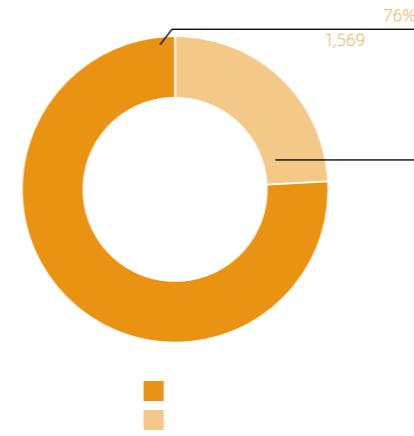



	%	22.69	23.66
	%	12.42	13.03
	%	20.27	25.00
		23	23
	%		



Salary Management Measures

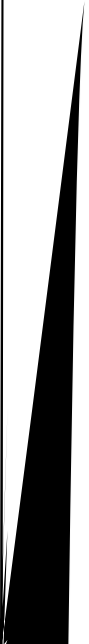



	%	100	100
		374.07	5,398.00
		8.57	5.18
	%	100	100



Employee Stock Ownership Plan,

Incentives of Listed Companies (for Trial Implementation)
Articles of Association
Ownership Plan

Measures for the Administration of Equity
Securities Law of the People's Republic of China
2022 Employee Stock



1

2

3

4

5







		6.13	17.53
		55	314
		1,145	3,155



31.1

1

83







